

1711 SERIES MAGNETIC SNAP-ON CONTACT PRESSURE GAUGE MODEL:1711



Applications:

1711 series magnetic snap on contact gauge is designed for automatic control and signals transfer. When the pressure gets to the set value, the contact opens/closes the circuits. It has a magnetic electric contact.

Specifications:

Nominal sizes:

4", 6"

Connection:

BSP 1/2" for 4", 6"

Protection class: IP 54 or IP 65 (for liquid filled 1712 series)

Scale Range, according to EN 837-1/5

Pressure ranges: 0 to 0.6/1/1.6/2.5/4/6/10/16/25/40/60/100/160/250/400/600/1000 bar

Vacuum range: -1 to 0 bar

Compound pressure: -1 to 0.6/1.5/3/5/9/15/24 bar

Operating Temperature:

Ambient: -20°C to 60°C, medium: 60°C maximum

Material Specification:

Case : Black steel case and DIN bayonet ring Window: instrument glass

Wetted parts: brass bourdon tube and connection,

Movement: brass

Contacts: Two contacts, one contact, Often open, often close

Maximum working voltage: AC380V or DC220V

Maximum current: 1A

Contact Power: 30VA

Options:

NPT, BSPT or other process connection

Non-standard dial range

Diaphragm seal in thread or flange end

*** 1711 series: 304 stainless steel case and DIN bayonet ring, brass wetted part**

*** 1712 series: 304 stainless steel case and DIN bayonet ring, brass wetted part, silicone oil filled.**

Mounting available

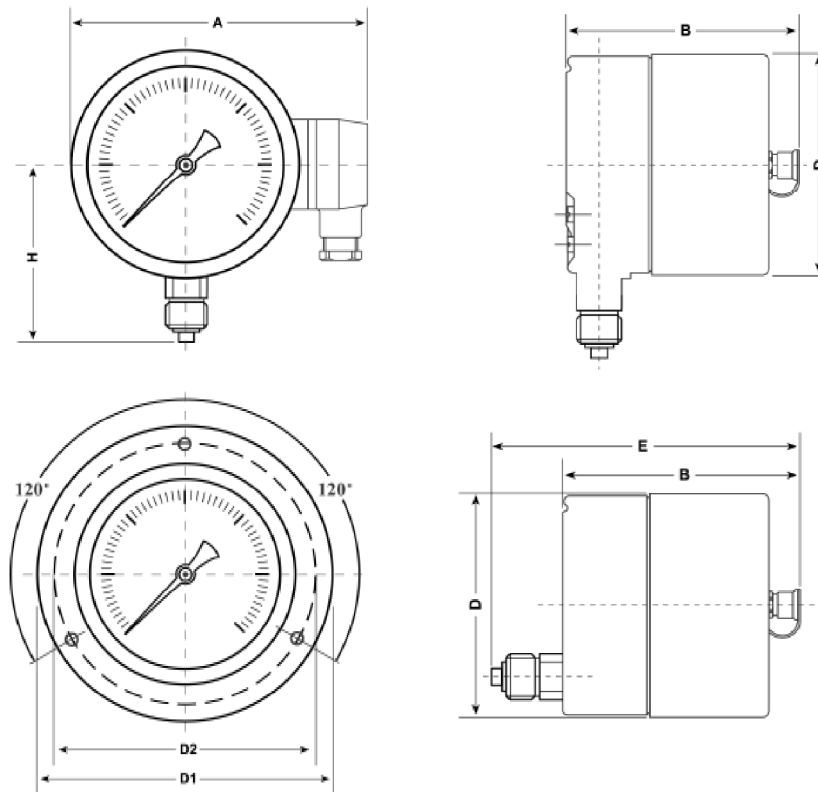

DIAL SIZE	A	B	D	H	D1	D2	E
4"	142	104	101.5	88	∅132	∅116	143
6"	193	98	161	125	∅178	∅166	150

dimensions are approximate and can be changed without prior notice